

MXI-ARRANGEMENT-4, LEVEL 2, UPBLAST  
 WITH CURB CAP AND/OR DISCHARGE CAP

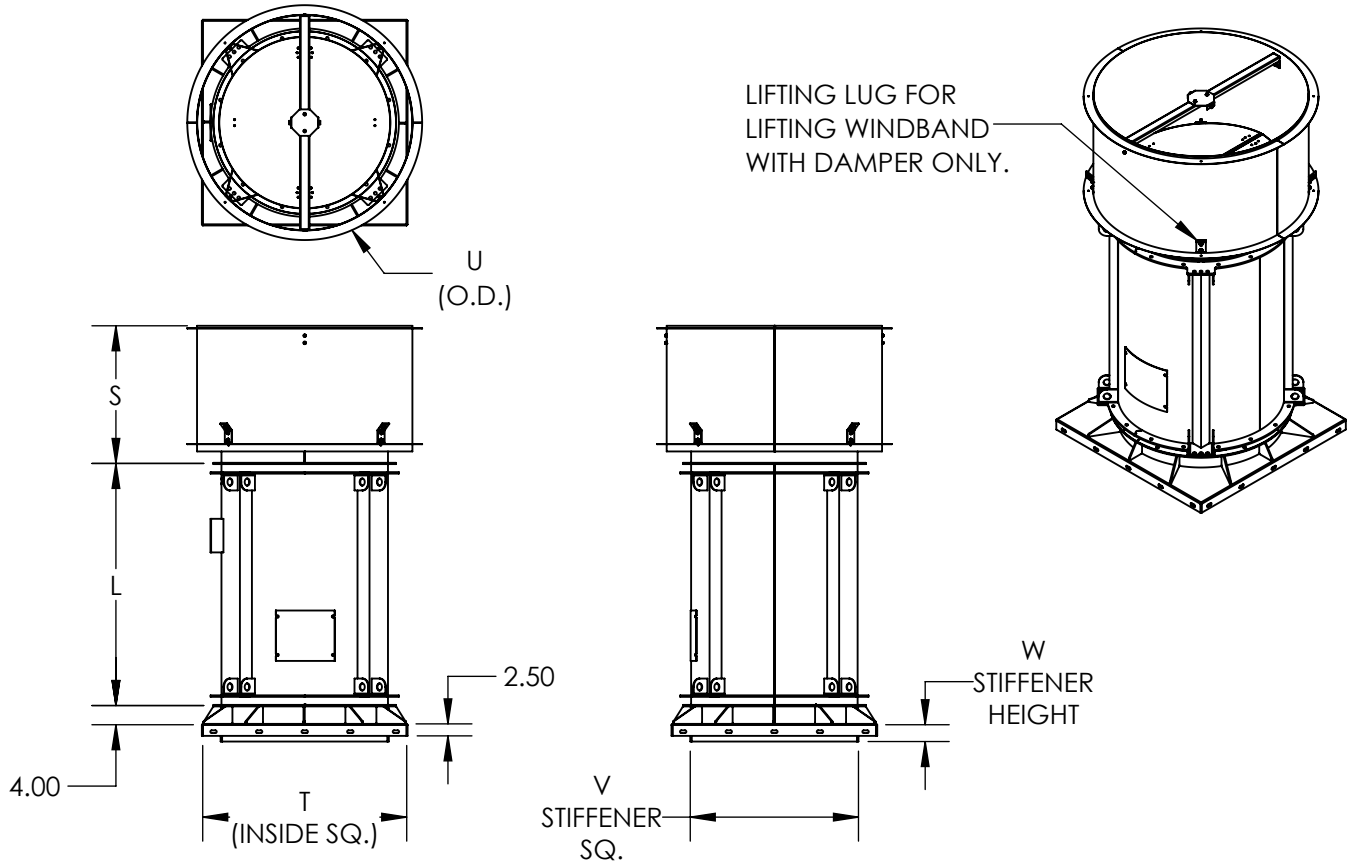

**DIMENSIONAL DATA**

SIZE	L	S	T	U	V	W	DISCH. CAP WEIGHT	CURB CAP WEIGHT	MXI FAN WEIGHT (LESS MOTOR)	MXI-AF FAN WEIGHT (LESS MOTOR)
122	25 1/8	20 5/16	24 1/2	27 1/16	18 1/4	3 1/2	51	89	180	181
135	27 13/16	21 1/4	26 1/2	28 15/16	20 1/8	3 1/2	57	99	214	213
150	30 7/8	22 5/16	28 1/2	31 1/8	22 5/16	3 1/2	62	108	250	254
165	33 15/16	23 1/16	30 1/2	32 5/8	23 13/16	3 1/2	67	119	285	290
182	37 7/16	24 5/16	33 1/2	35 1/16	26 3/16	3 1/2	83	147	352	357
200	41 3/16	25 9/16	36 1/2	38 5/8	28 3/4	3 1/2	94	164	426	430
222	45 11/16	27 1/16	39 1/2	41 11/16	31 13/16	3 1/2	105	181	535	528
245	50 7/16	28 11/16	42 1/2	48 15/16	35 1/16	3 1/2	124	192	636	632
270	55 9/16	30 7/16	45 1/2	52 7/16	38 9/16	3 1/2	137	207	762	771
300	61 3/4	35 1/2	51 1/2	56 5/8	42 3/4	3 1/2	190	314	937	927
330	68	37 9/16	55 1/2	60 7/8	47	3 1/2	249	341	1090	1102
365	75 1/8	40	60 1/2	65 13/16	51 7/8	3 1/2	238	378	1337	1334
402	82 3/4	42 9/16	66 1/2	71	57 1/8	3 1/2	270	443	1591	1549
445	91 5/8	48 1/2	72 1/2	77	63 1/4	3 1/2	336	524	1879	1825
490	100 7/8	51 5/8	78 1/2	83 3/8	69 9/16	3 1/2	385	581	2451	-
542	111 9/16	55 1/4	87	90 11/16	76 7/8	3 1/2	491	690	2903	-
600	123 1/2	59 1/4	95	98 13/16	85 1/16	3 1/2	558	770	3482	-

ALL THE DIMENSIONS ARE INCHES AND WEIGHTS ARE IN LBS.

MXI-ARRANGEMENT-4, LEVEL 2, UPBLAST  
 WITH CURB CAP AND/OR DISCHARGE CAP

**WINDBAND ASSEMBLY**

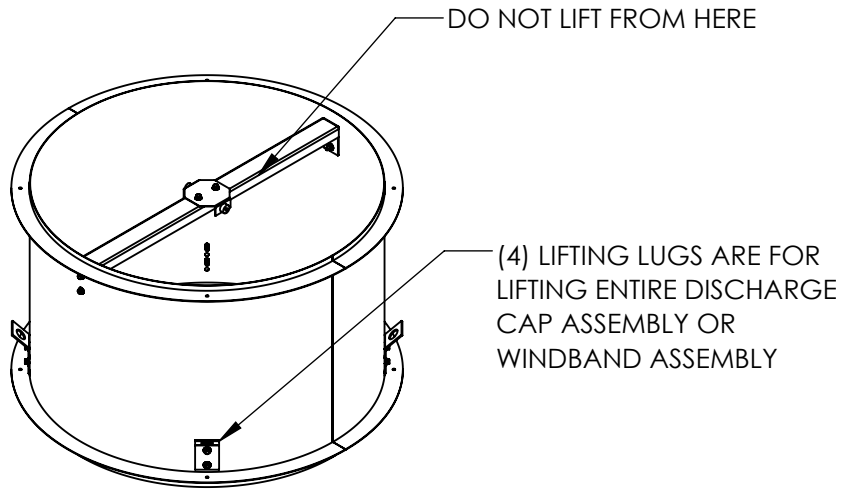

**DAMPER ASSEMBLY**

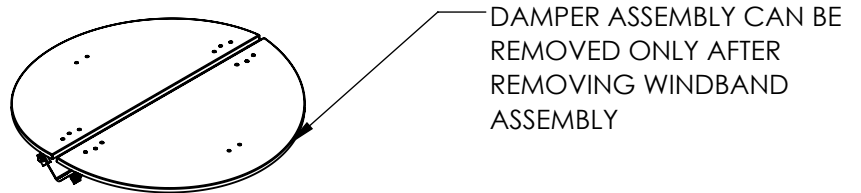

**AIRSHAFT ASSEMBLY**

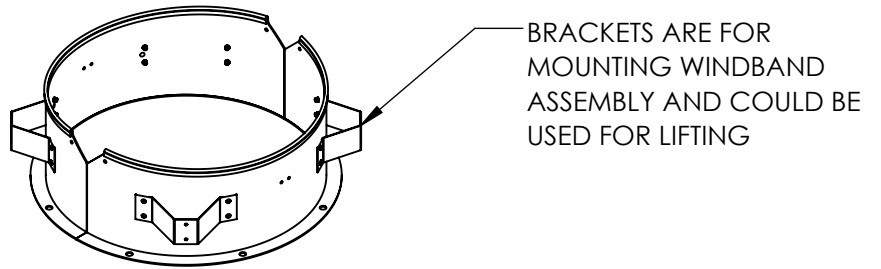

**DISCHARGE CAP EXPLODED VIEW**